

# Redland Dry & DryVent Ridge System

## FIXING INSTRUCTIONS

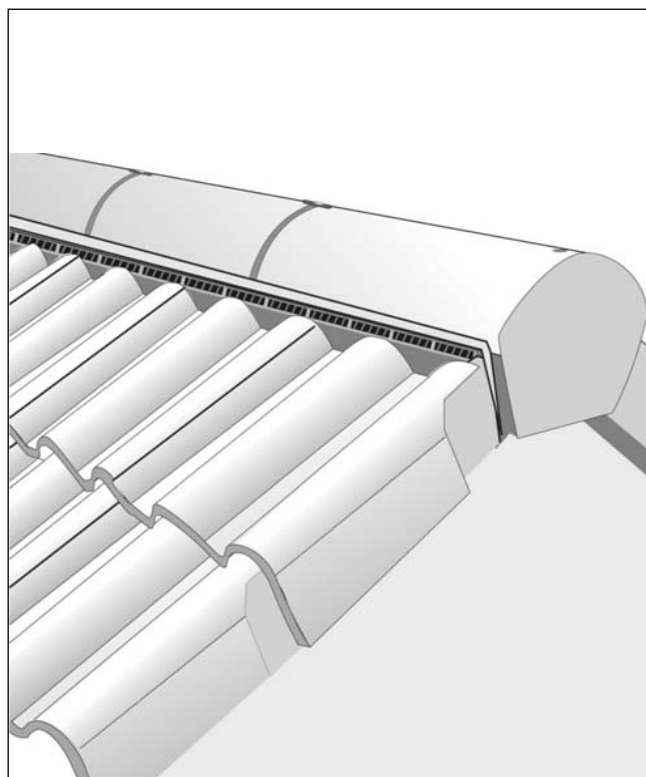

For Rigid Sarking, go to 1b.

**1a.** Lay underlay and batten the roof in the normal manner. For Dry Ridge, underlay should be dressed over the apex by no less than 150 mm. For DryVent Ridge, underlay should be left 30 mm short of the apex on either side of the roof.

### 1b. Rigid Sarking

Batten the roof in the normal manner. For DryVent Ridge, ensure that the rigid sarking is left short of the apex to allow a 10 mm gap. Also, the counterbattens must be extended to form an apex to support the ridge tree batten.

**1c. Do not fix the top tiling battens at this stage. With Rosemary Clay Plain Tiles, do not fix the top two tiling battens at this stage.**

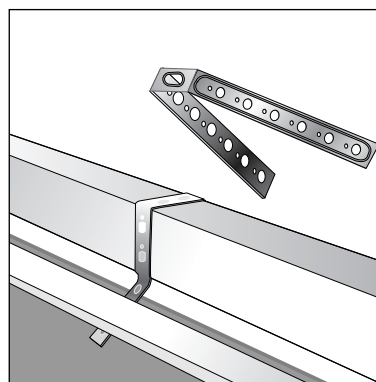

**2.** Hold the batten fixing strap so that the metal ridges are on top. Bend the strap downwards on both sides where marked "1", to form a U-shape. Position the ridge tree batten so it lies along the centre of the apex.

Place strap over the timber ridge batten. The height of the batten varies according to roof tile, ridge tile and roof pitch, refer to the pitch range and batten height table.

The ridge batten should finish flush with the outer face of the gable end, except when using Ambi-DryVerge when the batten should project 50 mm beyond the gable (60 mm for Mini Stonewold Dry Verge).

**3.** Fold the sides of the strap so they lie flat against the trusses.

Using the two 30 mm stainless steel annular ring shank nails provided, nail the strap to the rafter through the nail hole directly **below** the fold, one each side. Drive the nails as far into therafters as possible so there is no slack.

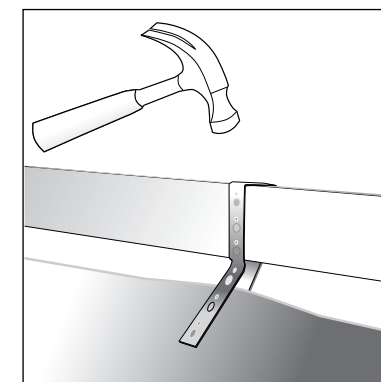

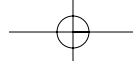

**4. Fix a batten strap to each rafter or counterbatten.**

Fix the top tiling battens on either side of the apex. The battens should be fixed according to the following table:

**Top Batten Distance Down From Apex**

	Cambrian	Stonewold II	Plain	Rosemary	All Profiles	All Slates	DuoPlain
<b>Below 35°</b>	30 mm	90 mm	-	-	55 mm	60 mm	40 mm
<b>Above 35°</b>	30 mm	90 mm	70 mm	35 mm Top Batten 75 mm Second Batten	55 mm	60 mm	40 mm

Tiling batten nails should be driven through the strap into rafter or counterbatten.

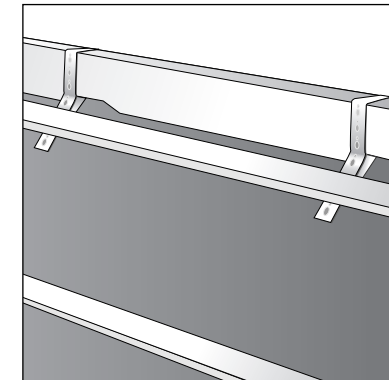

Lay roof tiles in the normal manner.

<b>PITCH RANGE AND RIDGE BATTEN HEIGHT FOR DRY &amp; DRYVENT RIDGE SYSTEMS (38 mm WIDTH)</b>																								
Tile / Slate Name	Rafter Pitch (Degrees)																							
	12.5	15	17.5	20	22.5	25	27.5	30	32.5	35	37.5	40	42.5	45	47.5	50	52.5	55	57.5	60	62.5	65	67.5	70
<b>Half Round</b>	<b>Batten Height (mm)</b>																							
Cambrian Slate	-	50	50	50	50	25	25	25	25	25	25	25	25	25	25	25	-	-	-	-	-	-	-	-
Landmark Slate	-	-	-	-	50	50	50	50	25	25	25	25	25	25	25	25	25	-	-	-	-	-	-	-
Saxon / Valentia	-	-	-	-	-	50	50	50	25	25	25	25	25	25	25	25	25	-	-	-	-	-	-	-
Richmond / Rathlin	-	-	-	-	50	50	50	50	25	25	25	25	25	25	25	25	25	-	-	-	-	-	-	-
Stonewold II	-	-	75	50	50	50	50	50	25	25	25	25	25*	-	-	-	-	-	-	-	-	-	-	-
Mini Stonewold	-	-	75	50	50	50	50	50	25	25	25	25	25	25	25	25	25	-	-	-	-	-	-	-
Heathland	-	-	-	-	-	-	-	-	50	25	25	25	25	25	25	25	25	25	25	25	25	-	-	-
Downland	-	-	-	-	-	-	-	-	50	25	25	25	25	25	25	25	25	25	25	25	25	-	-	-
Plain Tile	-	-	-	-	-	-	-	-	50	25	25	25	25	25	25	25	25	25	25	25	25	-	-	-
DuoPlain	-	-	-	-	50	50	50	50	25	25	25	25	25	25	25	25	25	25	25	25	-	-	-	-
Landmark Double Pantile	-	100	100	75	75	75	75	75	50	50	50	50	50	-	-	-	-	-	-	-	-	-	-	-
Grovebury	-	100	100	75	75	75	75	75	50	50	50	50	50	-	-	-	-	-	-	-	-	-	-	-
50 Double Roman	-	-	75	75	75	75	50	50	50	50	50	50	25	25	25	-	-	-	-	-	-	-	-	-
Regent	100	100	100	100	75	75	75	75	75	50	50	-	-	-	-	-	-	-	-	-	-	-	-	-
Renown	-	-	75	75	50	50	50	50	50	25	25	25	25	25	25	25	-	-	-	-	-	-	-	-
Norfolk Pantile	-	-	100	100	75	75	75	75	75	50	50	-	-	-	-	-	-	-	-	-	-	-	-	-
<b>Universal Angle</b>	<b>Batten Height (mm)</b>																							
Cambrian Slate	-	50	50	50	50	50	25	25	25	25	25	25	25	25	25	25	-	-	-	-	-	-	-	-
Landmark Slate	-	-	-	-	50	50	50	50	50	25	25	25	25	25	25	25	25	-	-	-	-	-	-	-
Saxon / Valentia	-	-	-	-	-	50	50	50	50	25	25	25	25	25	25	25	25	-	-	-	-	-	-	-
Richmond / Rathlin	-	-	-	-	50	50	50	50	50	25	25	25	25	25	25	25	25	-	-	-	-	-	-	-
Stonewold II	-	-	75	75	50	50	50	50	25	25	25	25	25*	-	-	-	-	-	-	-	-	-	-	-
Mini Stonewold	-	-	75	75	75	50	50	50	50	25	25	25	25	25	25	25	25	-	-	-	-	-	-	-
Plain Tile	-	-	-	-	-	-	-	-	50	25	25	25	25	25	25	25	25	25	25	-	-	-	-	-
<b>Rosemary Half Round</b>	<b>Batten Height (mm)</b>																							
Cambrian Slate	-	75	75	75	75	75	75	50	50	50	50	25	25	25	25	25	25	25	-	-	-	-	-	-
Landmark Slate	-	-	-	-	75	75	75	75	75	75	50	50	50	50	25	25	25	25	25	25	25	25	-	-
Saxon / Valentia	-	-	-	-	-	75	75	75	75	75	50	50	50	50	25	25	25	25	25	25	25	25	-	-
Richmond / Rathlin	-	-	-	-	75	75	75	75	75	75	50	50	50	50	25	25	25	25	25	25	25	25	-	-
Rosemary Clay	-	-	-	-	-	-	-	-	-	75	75	75	50	50	50	50	25	25	25	25	25	25	25	25

\*44° Maximum Pitch

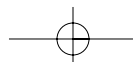

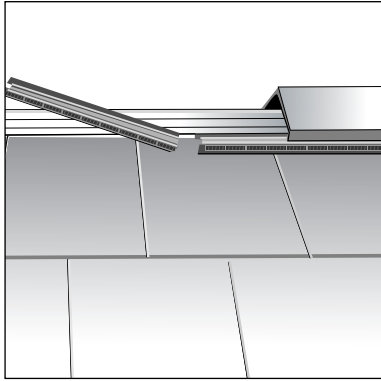

**5.** Lay Profile Filler Units along the roof tiles, snapping them together on either side of the ridge to receive the ridge tiles. If necessary, cut the final filler units to suit the ridge length. On gable end roofs, use a block-end ridge tile as the first ridge tile.

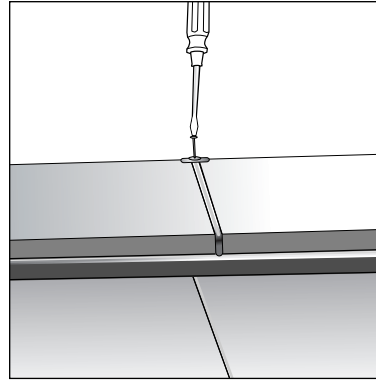

**7.** Slide the next ridge tile over the ridge to ridge seal. Ensuring the clamp plate is parallel to the ridge line, screw centrally into the ridge batten. Continue laying and fixing ridge tiles and ridge components along the ridge line.

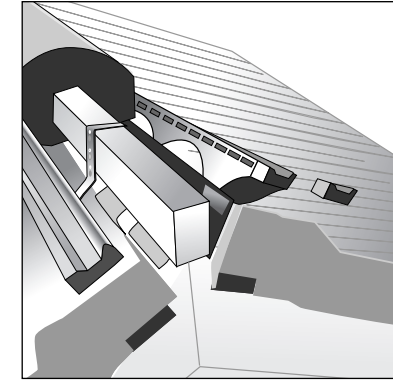

**9.** When using Cloaked Verge at the left-hand verge, cut a Profile Filler Unit along the line indicated and snap on the smaller piece to the final Profile Filler Unit to fill the open end.

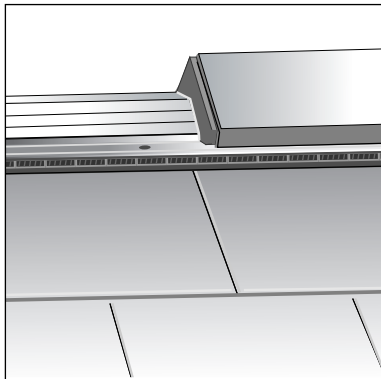

**6.** Slide the first ridge to ridge seal under the open end of the first ridge tile, ensuring that the full width of the seal is located in the trough of the Profile Filler Units.

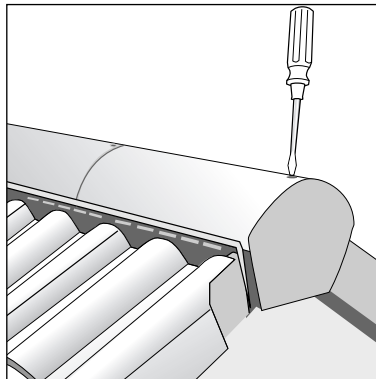

**8.** On gable end roofs, finish with a second block-end ridge tile. Fix the screw provided through the hole in the top of the tile into the ridge batten. On hip end roofs, carefully drill a 6 mm diameter hole, 100 mm in from the end of the last ridge tile and secure using the screw provided. Packs of additional screws are available separately.

When cutting the ridge tiles to length, ensure a clean cut face is achieved to abut closely against the ridge to ridge seal. Cut ridges should not be less than 200 mm long and should not be fixed within 450 mm of the end of a ridge line.

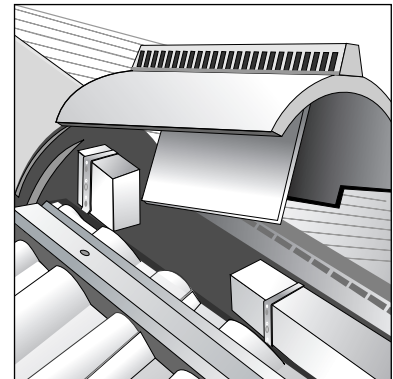

**10.** When fitting Ridge Vent Terminals, a 280 mm section of the ridge tree batten must be removed. Any fixing plates supplied are not required. The terminal is secured with the screw and clamping plate assembly.

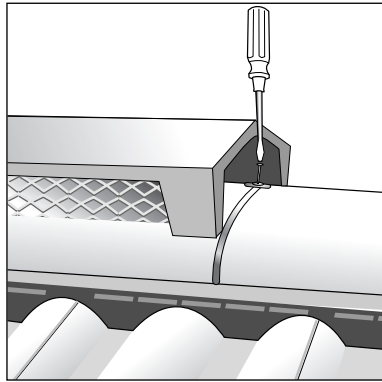

11. When fitting Gas Rue Terminals, a 370 mm section of the ridge tree batten must be removed. The terminal is secured by the clamping plate screwed into pre-drilled pilot holes in the ridge tree batten.

All tiles and slates except Norfolk Pantile:

**To comply with Building Regulations**, when using **Dry & DryVent Ridge** with a Gas Flue, one pack of Blanking Plates must be used with each terminal. Each pack contains sufficient inserts to blank off the required number of Profile Filler Units. A Blanking Plate must be inserted into the grille of every Profile Filler Unit within 600 mm each side of the Gas Flue Terminal.

Norfolk Pantile:

**To comply with Building Regulations**, when using **Dry & Dry Vent Ridge** with a Gas Flue, one pack of non-vented Profile Filler Units must be used with each terminal. Each pack contains sufficient non-vented Profile Filler Units to be installed within 600 mm each side of the Gas Flue Terminal.

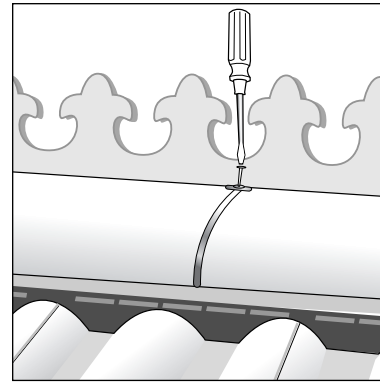
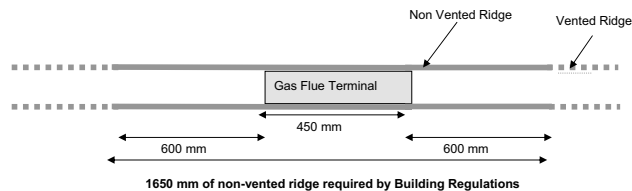

12. Slide the ornamental ridge tiles over the ridge to ridge seal and tighten.

On gable end roofs, finish the ridge line with an ornamental block-end ridge tile and secure using the screw provided.

On hip end roofs, finish the ridge line by carefully mitre cutting an ornamental block-end ridge tile and secure using the screw provided.

**Pack Contents**

DryVent Ridge Pack (DuoRidge Only)	Number of units per pack							Coverage (mm)	
	DryVent Filler Units	Batten fixing Strap	Half round ridge to ridge seal assembly	Universal angle ridge to ridge assembly	Rosemary half round ridge to ridge assembly	2.65 mm x 30 mm S/S Ring shank nail	Fixing Instructions	Filler Units	Pack
Slate Range with Half Round Ridge Tile	12	6	6	-	-	12	✓	450	2700
Rosemary Clay	8	4	-	-	6	8	✓	450	1800
Heathland & Downland	8	4	6	-	-	8	✓	450	1800
Plain Tile & DuoPlain	12	6	6	-	-	12	✓	450	2700
Landmark Double Pantile + Grovebury + 50 Double Roman + Regent + Renown	18	6	6	-	-	12	✓	300	2700
Norfolk Pantile	28	6	6	-	-	12	✓	200	2800
Slate Range with Universal Angle Ridge Tile	12	6	-	6	-	12	✓	450	2700
Ornamental Tile with Universal Angle Ridge Tile	12	6	-	6	-	12	✓	450	2700

Each pack contains sufficient components to fix 6 ridge tiles

**Gas Flue Conversion**

Solution to blank off DryVent Ridge	Number of units		Coverage (mm)		
	Blanking Plates	Non-Vented Grille Filler	Blanking Plates	Non-Vented Grille Filler	Vented Ridge
Slate and Plain Tile ranges	8	-	450	-	1800
Landmark Double Pantile + Grovebury + 50 Double Roman + Regent + Renown	12	-	300	-	1800
Norfolk Pantile	-	18	-	200	1800

# Redland

## Dry Vent Ridge System

### Additional Instructions for Landmark, Richmond and Rathlin Slates where the Roof Pitch is below 25°

#### FIXING INSTRUCTIONS

1. With the exception of the top piece of underlay and top tiling batten, lay and batten the roof in the normal manner. Lay the top piece of underlay so that it extends at least 150 mm beyond the apex of the roof. Fix the underlay to the rafters using 25 mm long clout head felt nails, leaving the top 200 mm unfixed. Fold the unfixed section of underlay towards you. To determine the ridge batten height see the pitch range and batten height table. Fix the ridge batten to each rafter with the ridge batten straps supplied.

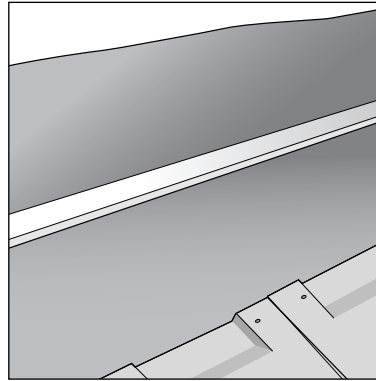

2. Fold the unfixed (200 mm) underlay back over the ridge batten. Position the top batten 60 mm down from the apex and nail fix through the underlay and ridge batten straps.

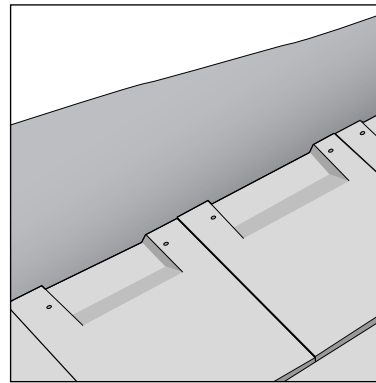

3. Lay and mechanically fix the top slate course (marked T on the head of the slate).

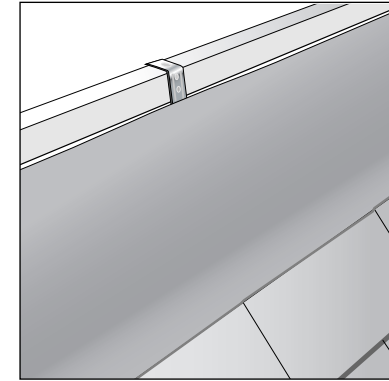

4. Turn the underlay over the head of the top slates, and dress down the surface of the slates, pulling it taut to ensure a clear 10 mm air path between the top slates and the ridge batten. Repeat instructions for the opposite side of the ridge, before installing the profile filler units and the Ridge Tiles.

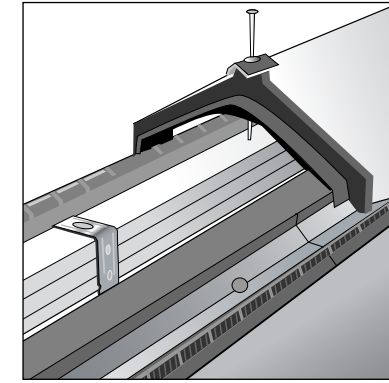

5. Install the DryVent Ridge System as shown previously. Pull the underlay taut as you screw the ridge fixing into the ridge batten.

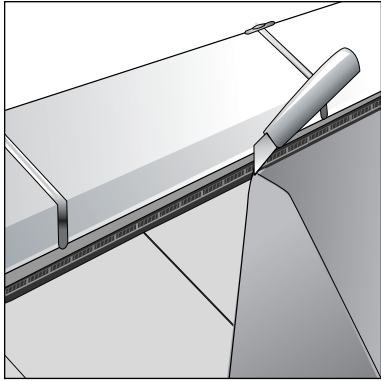

**6.** Using the outer edge of the profile filler unit as a guide and a sharp knife, carefully trim off the excess underlay without scoring the surface of the tiles.

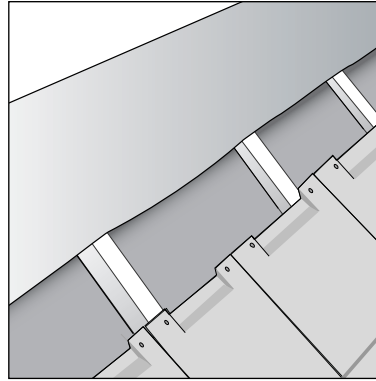

**8.** Lay a 300 mm piece of underlay so that it extends at least 150 mm beyond the apex of the roof. Fix the underlay to the counterbattens using 25 mm long clout head felt nails, leaving the top 200 mm unfix.

**FIXING INSTRUCTIONS FOR USE WHEN UNDERLAY IS LAID DIRECTLY ON TOP OF RIGID SARKING**

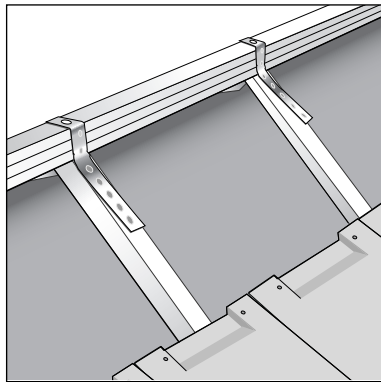

**7.** With the exception of the lop batten, lay the underlay and batten the roof in the normal manner. Ensure that the rigid sarking is left short of the apex to allow a 10 mm air gap and that the counterbattens are extended to form an apex to support the ridge tree batten. To determine the ridge batten height see the pitch range and batten height table. Fix the ridge batten to each counterbatten with the ridge batten straps supplied.

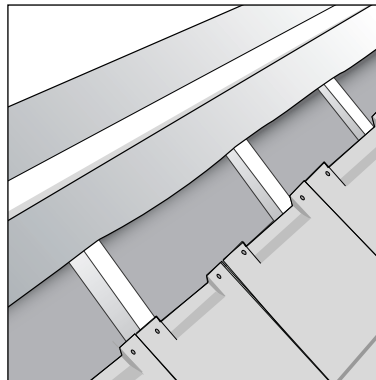

**9.** Position the top batten 60 mm from the apex and nail fix through the underlay and ridge batten straps.

**10.** Continue as described in instruction 3 of additional instruction.